

TECHNICAL DATA:

LIGHT RADIAL DRILLING MACHINE GUARDS - LRTS & LRTL - SIDE OPENING

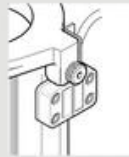

Interlock Option

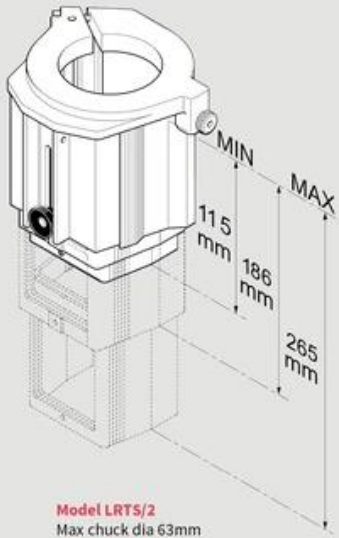

Model LRTS/2
Max chuck dia 63mm

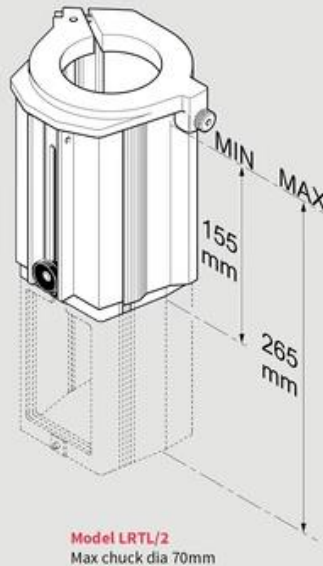

Model LRTL/2
Max chuck dia 70mm

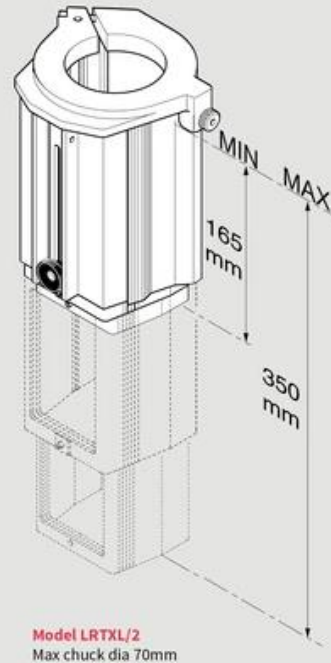

Model LRTXL/2
Max chuck dia 70mm

TECHNICAL DATA:

DIFFERENT TYPES OF TOP FIXINGS TO SUIT DRILLING MACHINES DEPTH STOP/NON ROTATING COLLARS

No1 (LRT)

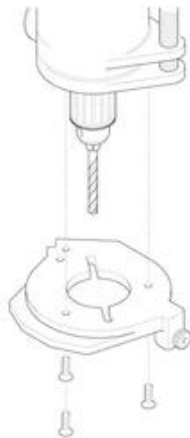

This is for fitting under the Bearing Housing and can take the place of the dust cover plate.

Where quill retracts into the Head it is fitted by drilling and tapping the underneath side of the head and bolted by means of countersunk screws to the machine.

No2 (LRT)



This is an integral clamp which can be bored out to suit any non-rotating collar size from 47 to 92mm.

On some drilling machines it may be necessary to raise the stop-gauge castings to expose this collar, 93 < 109mm Dia require a special adaptor.